

Showmanship - Seniors

High Blue = 100% - 92% (Enters Medal Program) Blue = 92% - 85% Red = 84% - 70% White = 70%

#	Comments	Danish	Score	Placing
343	prompt, keep eyes up, smooth light circle, straight back some registers, would like to see more work in front. did forehand work instead of horse straight to judge	W	69	2
323	well turned out, prompt, smooth circle, balanced half straight back → closed fluid horse touch straight to judge, fluid 270 work to plant pivot foot	HB	92	1
304	prompt, work for less registers, in circle angled back. work to plant pivot foot straight to judge angle set up fluid 270	B	85	2
321	keep eyes up, broke in each ✓ excellent. well closed work to plant pivot foot maintain forward motion, straight to judge	R	82	4
345	well turned out, small breaks in circle keep eyes up, smooth straight back work to plant pivot foot, greater than 450 work for quicker set up fluid 270	R	78	6
351	circle to steady do not touch around you clear than 90° well turned out, smooth light circle forehand falling behind smooth back work to plant pivot foot, straight to judge work to plant pivot foot	R	79	5
341	well turned out, smooth round foot circle, smooth straight back, no close back, fluid 450 angle at stretch, fluid 270	R	79 74	
305	prompt, smooth around circle, work for smoother back danger zone work to pivot foot, straight to judge work for circle set up half pivot set up	R	75	8
322	well turned out, some right in foot circle, broke to work, work for straighter back, work for forward movement in hand angle to stretch, work for	R	76	7
320	wrong side of cone, no trot, but tried, less regist in back keep two hands on lead, no 450 straight to judge off pattern	W	65	
335	prompt, well turned out, excellent trot circle, work for straighter back, work to plant pivot angle to stretch work for quicker set up	BR	80 83	3
364	very clean horse, well turned out, did not move to offside work to plant pivot foot, greater than 450, angle to stretch keep eyes up danger zone to 270	W	68	

Showmanship - Intermediates

High Blue = 100% - 92% (Enters Medal Program) Blue = 92% - 85% Red = 84% - 70% White = 70% -

#	Comments	Danish	Score	Placing
217	nice trot - quarters did not do haunch turn 2nd	75-	R	4
206	no trot @ B work on quarters at B	65-	W	76
207	drags out trot, or be on outside over turned	55	W	78
234	no trot go closer to C no haunch OP	50	W	84
292	no trot more job work on haunch	70-	W	56
214	low trot work on haunch need to move bullet of OP	50	W	10
225	trot straight to judge good job	85!	B	1
215	Bad trot no job	70!	R	50
235	good job trot straight to judge	75-	R	32
212	no trot more walk 1/4 to early	85!	B	2
231	no trot work on haunch OP	8!	W	11



Showmanship - Juniors

High Blue = 100% - 92% (Enters Medal Program) Blue = 92% - 85% Red = 84% - 70% White = 70% -

#	Comments	Danish	Score	Placing
107	walk on belly me job	R	70	5
123	me back me trot no hand	R	80	4
108	no feet no trot	W	60	6
124	walk on back me on turn	R	82	3
105	walked out of turn me job - walk me on	B	85	2
116	great job good backing	B	90	1

Showmanship - Intermediates

High Blue = 100% - 92% (Enters Medal Program) Blue = 92% - 85% Red = 84% - 70% White = 70% -

#	Comments	Danish	Score	Placing
217	nice trot - quarters did not do haunch turn 2nd	75-	R	4
206	no trot @ B work on quarters at	65-	W	76
207	drags out trot, or be on off side over turned	55	W	78
234	no trot go closer to C no haunch OP	50	W	84
292	no trot more job work on haunch	70-	W	56
214	low trot work on haunch need to move bullet of OP	50	W	10
225	trot straight to judge good job	85!	B	1
215	Bad trot no job	70!	R	50
235	good job trot straight to judge	75-	R	32
212	no trot more walk 1/4 to early	85!	B	2
231	no trot work on haunch OP	8!	W	11



Showmanship - Novice

High Blue = 100% - 92% (Enters Medal Program) Blue = 92% - 85% Red = 84% - 70% White = 70% -

#	Comments	Danish	Score	Placing
60	gave yourself more room from line OP trotted around B	W	50	4
101	gave yourself more space from line - wrong way around C. OP	W	60	3
56	walk not tried to judge line 50% well might not	B	85	1
92	walk on 1/4 walk do judge	R	80	2

SHOWMANSHIP

BRONZE MEDAL

PATTERN # 1

1. Start at A.
2. Trot from A to B. (+)
3. At B, stop. Turn 360-degrees on the haunches. Stop. (+) *1 step*
4. Walk to C. Stop. ✓
5. Back four steps, pause, step forward to original position. Stop. ?
6. Turn 90-degrees to the right. (+) ✓
7. Trot to D and set up for inspection. ✓
8. After inspection, judge will ask a question about the parts of the horse.
9. Exhibitor is excused to lineup.

Cones should be 30' apart

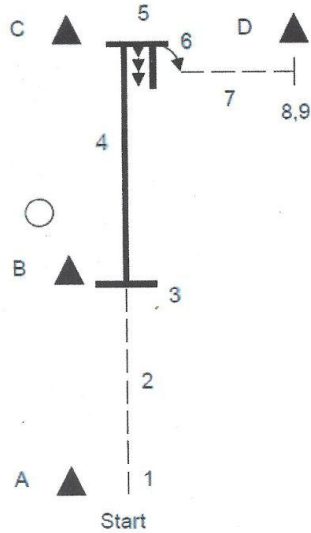

Rider # 235

Comments: _____

Medal: YES

NO
[Signature]

Judges Signature: _____

SHOWMANSHIP

BRONZE MEDAL

PATTERN # 1

1. Start at A.
2. Trot from A to B.
3. At B, stop. Turn 360-degrees on the haunches. Stop. *with PPS*
4. Walk to C. Stop. ✓
5. Back four steps, pause, step forward to original position. Stop. +
6. Turn 90-degrees to the right. +
7. Trot to D and set up for inspection. +
8. After inspection, judge will ask a question about the parts of the horse. *Forder*
9. Exhibitor is excused to lineup.

Cones should be 30' apart

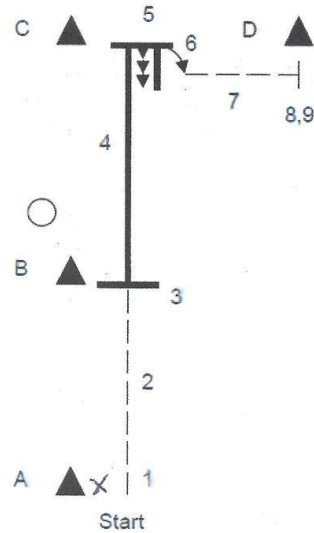

Rider # 335

Comments: _____

Medal: YES

NO

Judges Signature: *[Signature]*

SHOWMANSHIP

SUPREME AWARD

PATTERN # 1

323

1. Start at A.
2. Trot a serpentine around cones. Stop at C. *+*
3. Side pass about five steps to the left. *+*
4. Turn 270-degrees on right haunch. *(4) > wrap*
5. Walk to D. Stop. Back three steps *+*
6. Turn 270-degrees on right haunch. *> wrap*
7. Trot to and around E. Stop where indicated. Turn 180-degrees on right forehand. *+*
8. Stay on the off side. *+*
9. Walk half way to F. Half way, begin trotting. Stop and set up from off side at F. *+*
10. After inspection, pick up any of four feet directed by the judge.
11. Exhibitor is excused to line-up.

#346

D & E are 60' apart
F, E, A & D, C are 30' apart
Serpentine cones are 15' apart

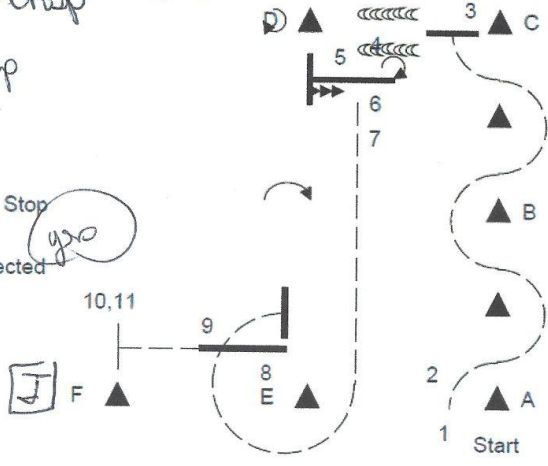

Rider # _____

Comments: _____

Point: YES NO

Judges Signature: *K. M. [Signature]*